

# Automated Dielectric Breakdown Test Set for Insulating Materials



## Testing Applications

Designed to measure dielectric breakdown and dielectric strength of a wide range of solid electrical insulating materials, at commercial power frequencies, within the ASTM D149 and IEC 60243-1 standards as well as other comparable international standards.

## Models Available

- 6CC20-0.8/D149
- 6CC50-2/D149
- 6CC100-5/D149
- 6TC4100-10/50-2/D149
- 4TC40-10/D149
- 4TC100-10/D149



- Standard **output voltages** up to **100 kV AC and DC**
- **Rugged**, mobile **steel cabinet**
- **Integrated** test chamber

AC, 100 kV



## Safety and Design Features

- Programmable Logic Controller and Operator Terminal utilized to control all aspects of test sequences
- Selectable automatic or manual operating modes
- Programmable rate of rise
- Over-voltage preset
- Peak-reading memory voltmeter
- Circuit breaker protection
- Test chamber with safety interlock, stress relief shielding, and transparent door
- Fast-acting as well as thermal overload protection
- Over-current trip point is adjustable from 10% to 110% of rated output current
- Rugged steel cabinet with durable painted finish
- Casters for ease of mobility
- Writing shelf on front of cabinet
- Fork lifting provisions
- Two copies of operation/maintenance manual

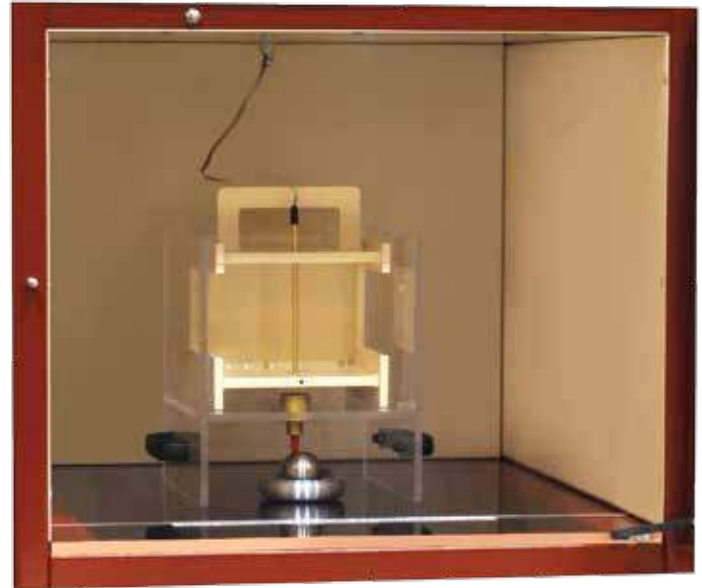

## 600C Series Controls

- Auto-ranging display of voltage and current. Accuracy of  $\pm 0.8\%$  of reading + 0.2% of range +LSD.
- Failure memory voltmeter function
- Auto-voltage, over-voltage, and over-current setpoint
- Stop watch, duration, dwell timer functions
- Auto-step and auto-cycle functions
- Motorized regulator
- Variable ramp rate (desired rate of rise may be entered)
- Ethernet port
- Graphic display

## Software Package

Specific test parameters can be entered or previous test files or "recipes" can be recalled for easy test duplication.

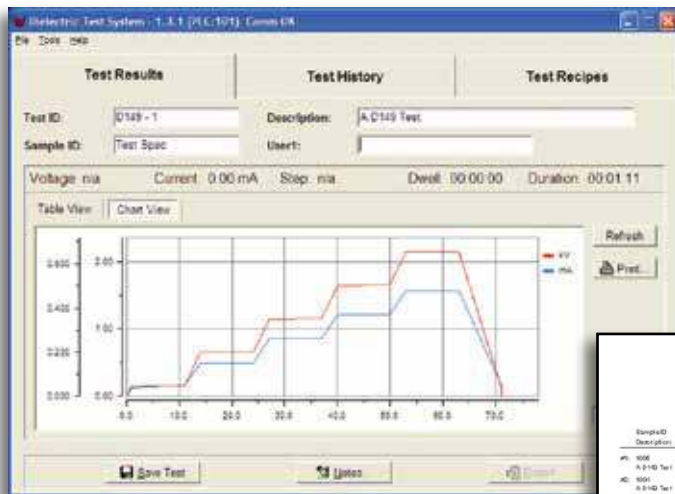

Phenix Technologies						
Industrial Drive Accident, MD, 21520 (301) 748-6318						
Test No: 0149-1						
SampleID Description	Date	Time	Result	Failure Voltage	Maximum Voltage	Current
PH-1006 A-9140 Test	3/27/2012	10:12:00 AM	Test Complete	NA	2.000 V	0.400 mA
PH-1006 A-9140 Test	3/27/2012	10:11:30 AM	Test Complete	NA	2.000 V	0.400 mA
PH-1005 A-9140 Test	3/27/2012	10:10:04 AM	Test Complete	NA	2.000 V	0.400 mA
PH-1002 A-9140 Test	3/27/2012	10:08:17 AM	Test Complete	NA	2.000 V	0.400 mA
PH-1001 A-9140 Test	3/27/2012	10:08:38 AM	Test Complete	NA	2.000 V	0.400 mA
				Avg:	2.0000 V	0.4000 mA

Test results are graphically displayed to pin-point real-time voltage, current, dwell, and duration characteristics.

Results can be stored in a variety of configurations. (Computer is not included.)

## Test Fixtures

A wide variety of test fixtures with electrodes are available.

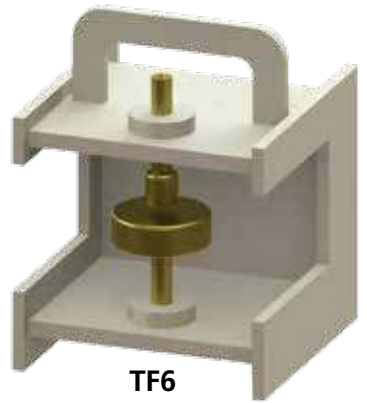
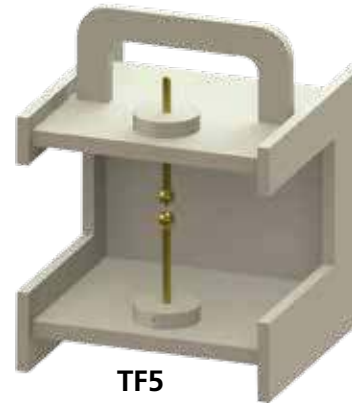
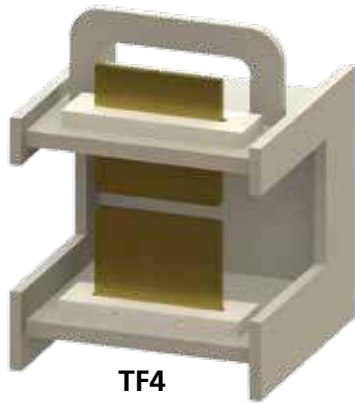
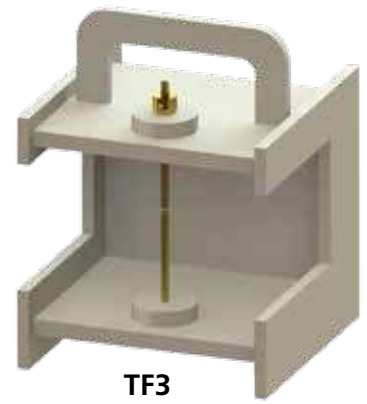
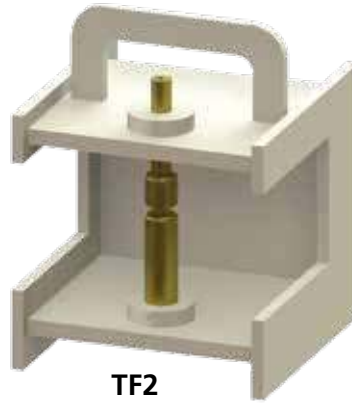
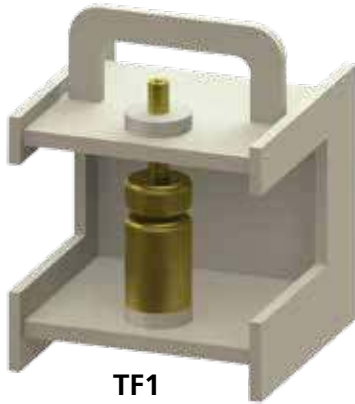

The most common are:

**TF1** : Opposing cylinders 2" (51 mm) in diameter, 1" (25 mm) thick with edges rounded to 0.25" (6.44 mm) radius.

**TF2** : Opposing cylinders 1" (25 mm) in diameter, 1" (25 mm) thick with (3.2 mm) radius.

**TF3** : Opposing cylinder rods 0.25" (6.4 mm) in diameter, with edges rounded to 0.0313" (0.8 mm) radius.

**TF4** : Flat plates 0.25" (6.4 mm) thick and 4.25" (108 mm) wide with edges square and ends rounded to 0.125" (3.2 mm) radius.

**TF5** : Hemispherical electrodes 0.5" (12.7 mm) in diameter.

**TF6** : Opposing cylinders: the lower one 3" (75 mm) in diameter, 0.6" (15 mm) thick; the upper one 1" (25 mm) in diameter, 1" (25 mm) thick; with edges of both rounded to 0.12" (3 mm) radius.



## Options

- Non-heated oil bath for test fixtures
- Heated oil bath for test fixtures
- Combination AC/DC supplies or DC only units
- Ground Stick, 2-piece design, with a 25' (8 m) ground lead
- Discharge Stick (100 kV, 100 k $\Omega$ , 50 kJ), 2-piece design with a 25' (8m) ground lead

### AC UNITS

MODEL		6CC20-0.8/D149	6CC50-2/D149	6CC100-5/D149	
INPUT	Voltage / Current	120 V, 12 A 230 V, 7 A	120 V, 23 A 230 V, 13 A	230 V, 25 A	
	Frequency	single phase 50 or 60 Hz (one must be specified)			
OUTPUT	Voltage / Current	≈0-20 kVAC, 40 mA ≈0-3 kVAC, 100 mA	≈0-50 kVAC, 40 mA ≈0-5 kVAC, 100 mA	≈0-100 kVAC, 50 mA ≈0-10 kVAC, 100 mA	
DUTY CYCLES	Continuous	for breakdown testing			
	1 hr ON/1 hr Off	0.8 kVA	2.0 kVA	5.0 kVA	
DIMENSIONS & WEIGHTS	Overall	Length	52" (1321 mm)	52" (1321 mm)	62" (1575 mm)
		Width	30" (762 mm)	30" (762 mm)	35" (889 mm)
		Height	68" (1727 mm)	68" (1727 mm)	68" (1727 mm)
		Weight	550 lbs (249 kgs)	600 lbs (272 kgs)	1050 lbs (476 kgs)
	Test Chamber	Length	29" (737 mm)	29" (737 mm)	34" (864 mm)
		Width	26" (660 mm)	26" (660 mm)	31" (787 mm)
	Height	22" (559 mm)	22" (559 mm)	22" (559 mm)	

### AC/DC UNITS

MODEL		6TC4100-10/50-2/D149
INPUT	Voltage / Current	120 V, 25 A 230 V, 13 A
	Frequency	single phase 50 or 60 Hz (one must be specified)
OUTPUT	Voltage / Current	≈0-50 kVAC, 40 mA ≈0-100 kVDC, 10 mA
DUTY CYCLES	Continuous	for breakdown testing
	1 hr ON/1 hr Off	2.0 kVA
DIMENSIONS & WEIGHTS	Overall	consult factory

### DC UNITS

MODEL		4TC40-10/D149	4TC100-10/D149
INPUT	Voltage / Current	120 V, 8 A 230 V, 5 A	120 V, 14 A 230 V, 8 A
	Frequency	single phase 50 or 60 Hz (one must be specified)	
OUTPUT	Voltage / Current	≈0-40 kVDC, 10 mA	≈0-100 kVDC, 10 mA
DUTY CYCLES	Continuous	for breakdown testing	
	1 hr ON/1 hr Off	400 W	1000 W
DIMENSIONS & WEIGHTS	Overall	consult factory	consult factory



## PHENIX TECHNOLOGIES

### WORLD HEADQUARTERS

**Phenix Technologies, Inc.**  
75 Speicher Drive  
Accident, MD 21520 USA  
Ph: +1.301.746.8118  
Fx: +1.301.895.5570  
Info@phenixtech.com

### BRANCH OFFICES

**Phenix Systems AG**  
Riehenstrasse 62A, 4058 Basel, Switzerland  
Ph: +41.61.383.2770, Fx: +41.61.383.2771, Info@phenixsystems.com

**Phenix Asia**  
Zhong Cheng Rd, Sec 1, No 177, 2F, Taipei 11148 Taiwan  
Ph: +886.2.2835.9738, Fx: +886.2.2835.9879, Info@phenixasia.com

