

Electronic AC and DC Loads

AC/THREE-PHASE LOAD ACL SERIES



- Frequency range up to 1,000 Hz
- Single and three-phase devices
- Parallel, star or delta connection
- Input voltage 280 V or 500 V
- Single-phase power from 500 ... 21,000 W
- 3-phase power from 3 x 1,400 ... 3 x 8,400 W
- User interface with 4.3" touchscreen
- Operation by mouse
- Operating modes CC, CR, CP, CV
- Arbitrary current waveforms
- Uninterrupted waveform change
- Synchronization to load input, line or extern
- Adjustable crest factor up to 4
- Automatic amplitude correction
- Phase shift combined with crest factor
- Harmonics up to 25th order, even and odd
- Phase cut from -180 ... 180°
- Manual on board

ACL Series – Brief Profile

ACL series loads are suitable for DC and AC voltages up to 1,000 Hz.

There are single-phase models as well as three-phase loads which combine 3 channels or phases, respectively, in one housing.

The brilliant 4.3" touchscreen makes operation easy and convenient. Different waveforms are defined directly via the user interface, from phase angle and crest factor to harmonics and arbitrary current waveforms. Phase shifting between load current and voltage is possible in conjunction with crest factor or phase angle control.

The measured values are displayed numerically for all channels/phases or displayed in an oscilloscope-like manner versus time in a graph.

The automatic amplitude correction keeps the RMS value of the current constant even with a variable crest factor.

Interfaces

- RS-232
- USB
- LAN
- GPIB
- CAN
- System bus for Master-Slave operation
- Analog
- Analog isolated

● Standard ○ Option — not available

Operating Modes

The ACL series loads have constant current, constant resistance, constant power and constant voltage modes (CC, CR, CP, CV Mode).
In AC operation, the set waveform is applied to the load current, independent of the input voltage. In resistance mode, the current level and waveform depend on the level and waveform of the input voltage. In power and voltage mode, the power or voltage is controlled by software by adjusting the input current.

Input Mode, Synchronization

The input mode defines the kind of voltage the electronic load expects at the input:

- DC: direct voltage
- AC: alternating voltage within the specified frequency range. Synchronization to
 - Input voltage
 - Line/mains voltage
 - External signal

Protection, Monitoring

- Adjustable overcurrent protection
- Overpower protection
- Overtemperature protection
- Overvoltage indication
- Undervoltage indication

I/O Port (Option ACL06)

Analog signals
in realtime!

All inputs and outputs of the optional I/O port are galvanically isolated from the load input. The control inputs can be operated by 2 ... 24 V.

Signals for:

- Analog load setting from 0 ... 5 V or 0 ... 10 V in CC mode
- Input mode (AC, DC)
- Synchronization source (input, line, extern)
- Load activation
- Control source selection (intern, extern)
- Trigger input
- Trigger output
- Synchronization input
- Remote shut-down input
- Analog voltage monitor output 0 ... 7 V/0 ... 10 V
- Analog current monitor output 0 ... 7 V/0 ... 10V
- Analog monitor outputs as proportional AC curve (realtime waveform capture) or rms value, selectable
- Master output to control slave devices
- Programmable digital output
- Status output for load input activation
- Status output for overload

Factory Calibration Certificate (FCC-ACLxx)

2 x for free

We supply a free Factory Calibration Certificate (FCC) with the devices. The calibration process is subject to supervision in accordance with DIN EN ISO 9001. This calibration certificate documents the traceability to national standards to illustrate the physical device in accordance with the International System of Units (SI). Within the 2-year warranty period, we will calibrate a second time free of charge if the respective device will have been registered:

<https://www.hoecherl-hackl.com/service/device-registration>

For use under laboratory conditions, H&H recommends a calibration interval of 2 years. This is an empirical value that can be used as a guide for the first period of use. Depending on the intended use, service life, relevance of the application and ambient conditions, the operator should adjust this interval accordingly.

Connection Examples

Single and 3-Phase Loads

Besides single-channel AC loads ACLS, the models of the ACLT series have been developed for loading three-phase systems. They combine 3 AC load channels in one housing. The 3 load channels can be used to load 3 different DUTs in AC or DC operation or to test a three-phase system. In the so-called balanced mode, all channels are loaded with the same setpoint and the same waveform. In synchronization mode Line, channel A synchronizes to the mains voltage, channels B and C are each phase-shifted by 120°. To increase the maximum load current, 2 or 3 channels of an ACLT three-phase device or up to 3 ACLS single-phase devices can be connected in parallel.

Star Connection with 3-Phase Load

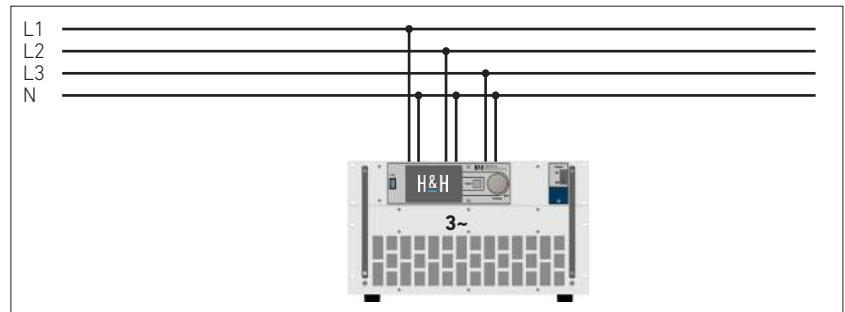

Star connection with ACLT 3-phase load

Delta Connection with 3 Single-Phase Loads in Master-Slave Connection

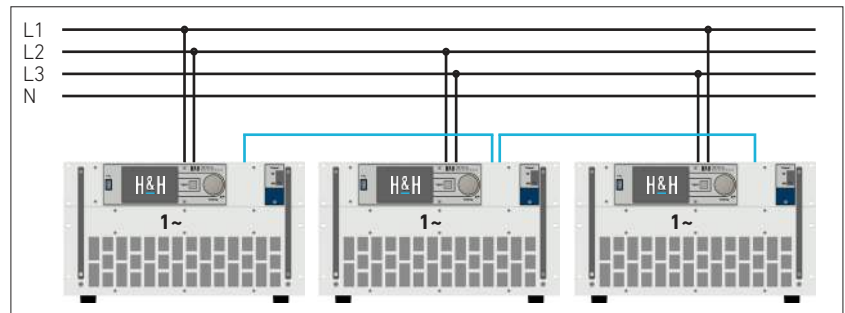

3-phase system in delta connection with 3 x ACLS single-phase loads in Master-Slave mode

Multi-Channel System with different DUTs

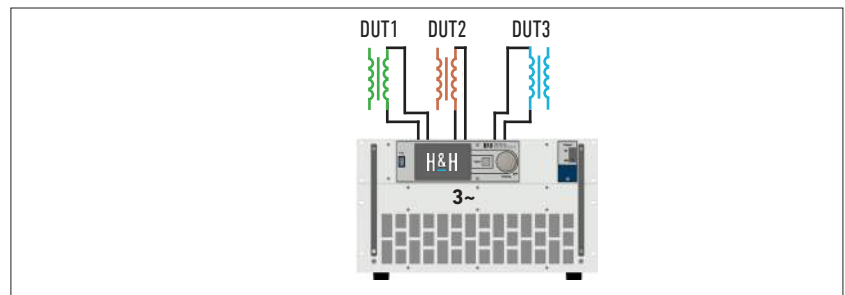

ACLT 3-phase load for 3 different DUTs

Parallel Connection of Several Channels

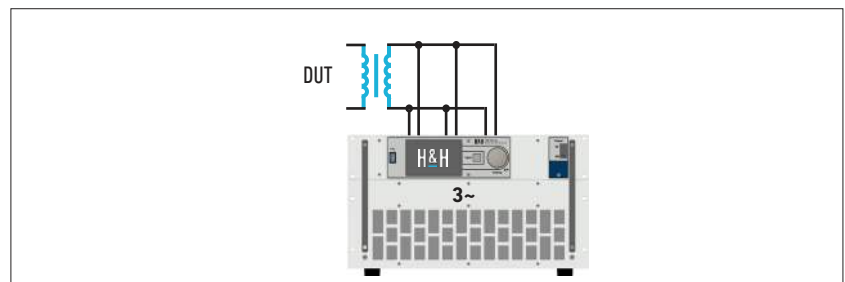

ACLT 3-phase load with paralleled inputs to increase current and power

User Interface



Operating elements

In addition to the load input, which is controlled by a large push-button, and the rotary knob for adjusting the setting value, the devices are operated by intuitive menu navigation via a 4.3" touch display like it is known with smartphones. If you prefer to operate by mouse, you can use the USB port on the front. The most common functions can be accessed via shortcuts. An associated help window is available for each dialog window, explaining the meaning of the respective elements. The help language can be set to German or English.

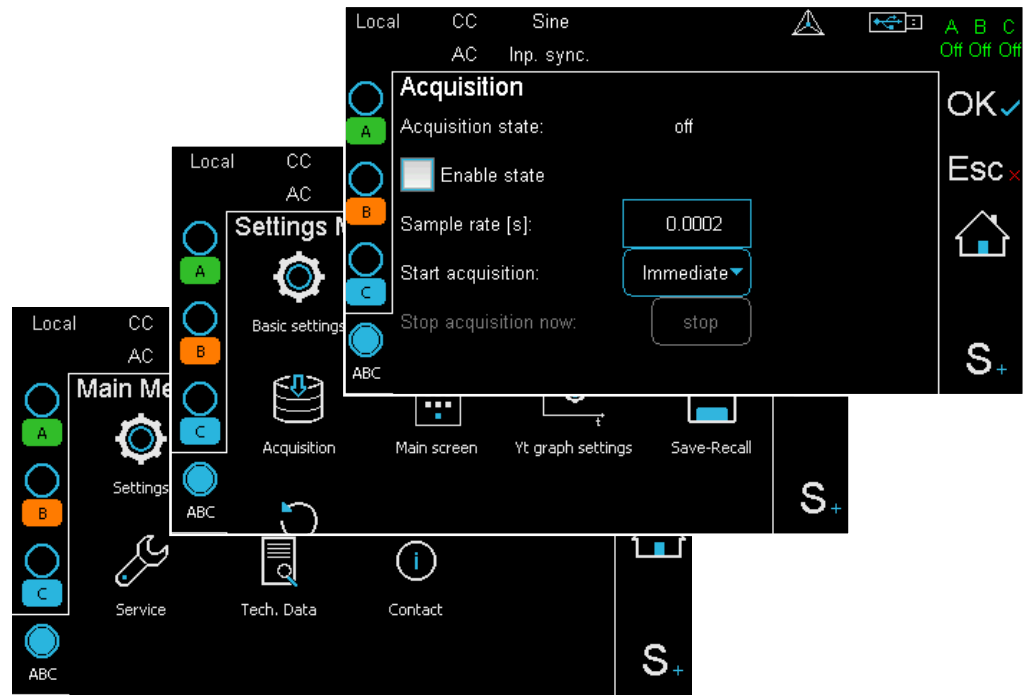

Menu-driven operation

Manual on Board

The ACL series user manual is stored in PDF format in the internal device memory. This can be copied to a USB flash drive or, conversely, updated from a USB flash drive if a newer version is available, e.g. after a firmware update with new functions. Thus, the user manual corresponding to the installed firmware doesn't get lost.

Crest Factor

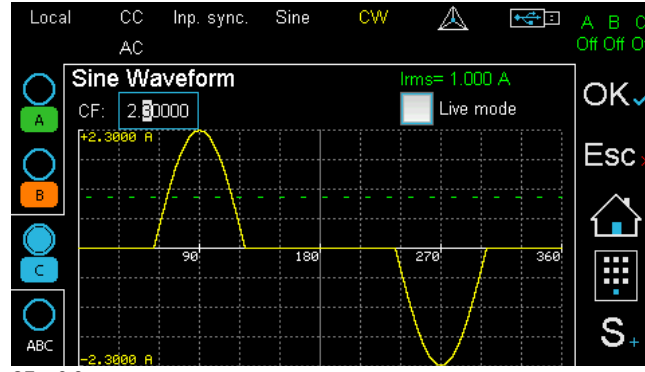

CF = 2.3

For sine waveforms the crest factor (CF) can be adjusted from 1.4142 to 4.0. The load corrects the resulting amplitude so that the RMS value remains constant.

Phase Cut, Phase Shift

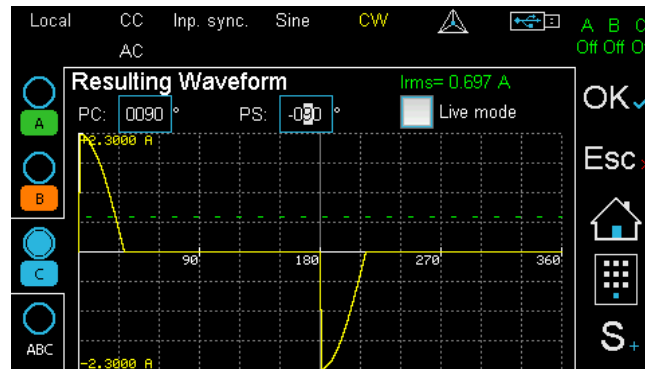

CF = 2, PC = 90°, PS = -90°

For each waveform, a phase cut (PC) and a phase shift (PS) of the current waveform can be set in the range from -180 to +180°. Depending on the phase angle, the RMS value of the current changes. The phase shift must be combined with a phase cut or a crest factor. A phase shift in the sense of a purely capacitive or inductive load is not possible.

Harmonics

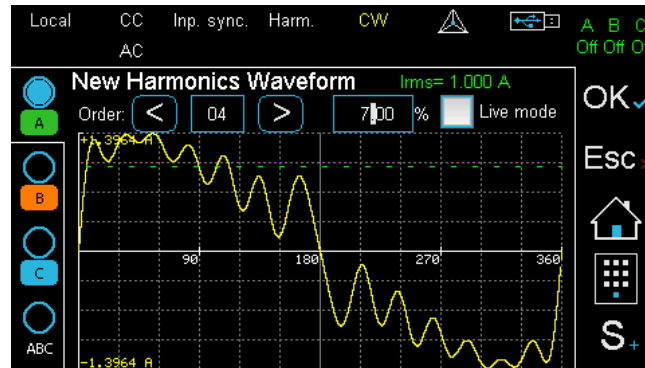

Sine with harmonics

In the waveform with harmonics, the amplitudes of the basic wave normalized from 0 to 1 as well as the up to 24 harmonics (even and odd) are summed up. The load corrects the resulting amplitude so that the RMS value remains constant.

Arbitrary Waveforms

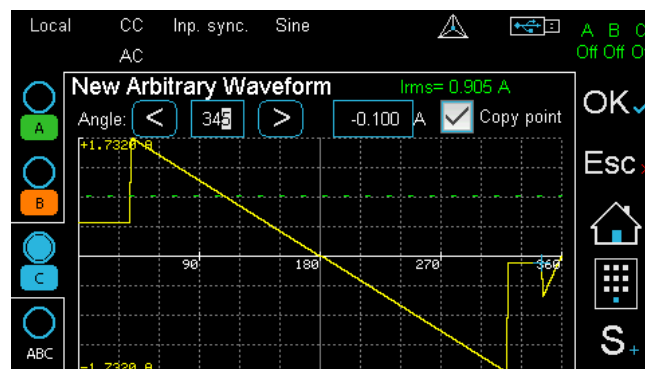

Arbitrary waveform on the base of a triangle

The definition of a period with 360 single points ensures maximum flexibility. The basis is either a sine, a square or a triangle signal, which can then be changed point by point. Depending on the waveform, the RMS value of the current changes.

Load Profile (List Function)

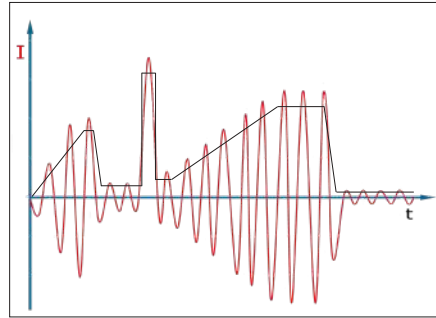

List function as RMS load profile

In all operating modes, the ACL load can emulate load profiles by means of the LIST function. Up to 300 setpoints of variable duration with associated ramp times are possible. In AC mode, the LIST function serves as a load profile of RMS values with the active waveform.

Voltage and current are measured synchronously and stored with a time stamp. Associated sampling times can be defined for each curve section.

Rectangular Function

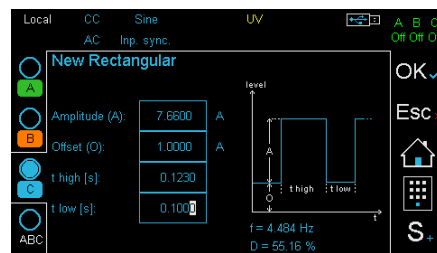

Likewise for all operating modes, the rectangle function offers a simple variant for changing between 2 setting values with adjustable durations. In AC mode, the rectangle function serves as a load profile of 2 rms values with the active waveform.

Data Acquisition (DAQ)

The electronic load can also store synchronous data records of voltage and current with time stamp in a defined interval, independent of the LIST function. Up to 40,000 data records are stored in a ring buffer. Once recording is complete, the data is read out via a data interface or transferred to a USB flash drive.

Static Data Logging

During slow processes, the electronic load can store voltage and current with timestamps directly on a USB flash drive in local mode. Sampling intervals are in the range of seconds.

Trigger Model

In remote operation via a data interface, several functions can be activated by a configurable trigger event:

- Activation/deactivation of list execution
- Activation/deactivation of data acquisition
- Activation/deactivation of load input
- Setting of all triggered setting values of all operating modes

Available trigger sources: Extern (with opt. I/O port), Bus.

Save Settings

In order to quickly reconstruct frequently recurring test tasks, the settings active in the electronic load can be stored non-volatile so that they can be reloaded later on. 9 memory positions are available.

The ACL load can optionally set the reset state when switching on, the last active settings at power-off or memory positions 1 to 9.

Watchdog Function

To protect the DUT from communication problems, the electronic load in digital remote control mode has a watchdog function that switches off the load input if the previously programmed watchdog delay time expires without the watchdog being reset.

The watchdog delay time is set by SCPI command, another command activates the watchdog.

When the watchdog is active, a control program must ensure that the command to reset the watchdog is periodically sent to the electronic load.

Display of Measurements

Depending on the focus on the display, more or less measured values are shown per channel. A single-phase ACLS device displays the following measured values in the main display: RMS value voltage, RMS value current, resistance, active power, apparent power, distortion reactive power, frequency, power factor, crest factor.

If all channels ABC of a multi-channel or three-phase device are focused, the effective value of the voltage and the effective value of the current are displayed for each channel.

All these measured variables can be queried via one of the data interfaces using a SCPI command.

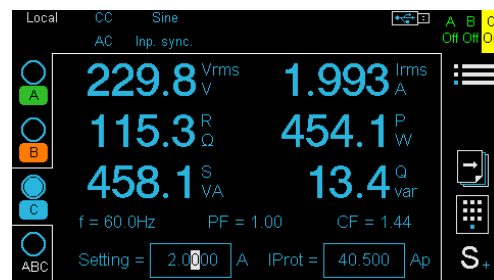

Main View 1 channel

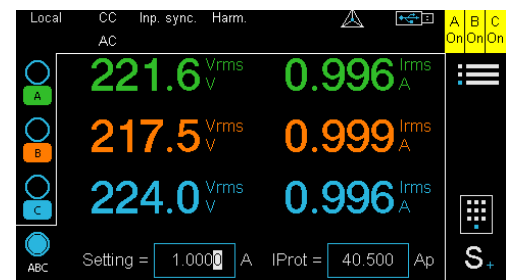

Main View 3 channels

Waveform Display

The last measured period of current and voltage is measured with 360 points and displayed in the Measured Waveform dialog.

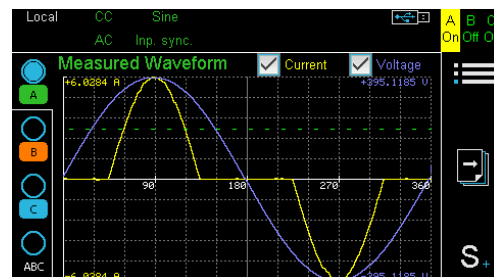

Crest factor affected current with AC voltage

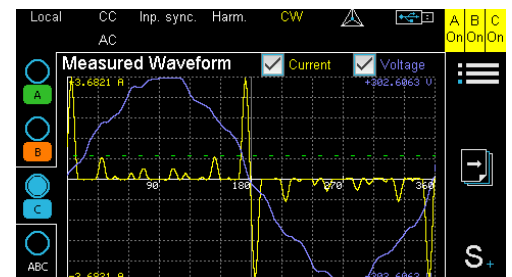

Current superimposed by Harmonics with line voltage

Yt Graph

The Yt-Graph shows the time course of the RMS value of voltage, current and/or power of the focused channel.

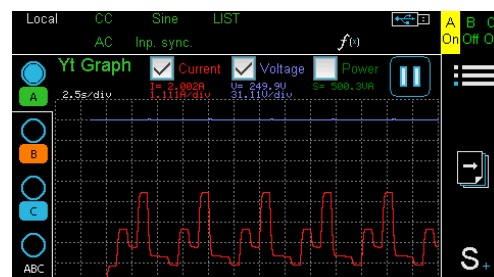

Yt Graph with running List function

Drivers



Current NI-certified LabVIEW drivers can be downloaded here:
www.ni.com/downloads/instrument-drivers/

Cooling

The units are air-cooled. In order to keep the operating noise low, for sizes starting from 5 U, the fans are controlled according to temperature and current.

Mechanics



Retractable handle

The ACL series is designed in stable 19" technology and can also be used as a desktop unit. From 5 U there are retractable heavy-duty carrying handles on the top of the unit. No separate mounting kits are required for 19" installation.

Castors (Option ACL14)



Heavy-load castors

Steerable castors can be mounted on big devices for easier transport. This often saves the need for a 19" cabinet. This option is available for units with 5 U and higher.

Options and Accessories

Order number	Article	Description
52-200-001-25	ACL02	GPIB interface
67-004-030-25	K-RS-SNM 9-9	RS-232 cable (Nullmodem cable)
53-100-009-25	ACL06	Galvanically isolated I/O port (3 x necessary for ACLT)
64-400-000-25	ACL14	Heavy-load castors for devices from 5 U (1 set = 4 pieces)
65-002-000-25	FCC-ACLSxx	Factory Calibration Certificate single-phase load
65-002-001-25	FCC-ACLTxx	Factory Calibration Certificate 3-phase load
63-000-001-25	PH3/7.62-BU41	Additional mating connector for load terminal single-phase load up to 40 A
63-000-002-25	PH3/10.16-BU76	Additional mating connector for load terminal single-phase load up to 75 A
63-000-003-25	PH3/15-BU125	Additional mating connector for load terminal single-phase load up to 120 A
63-000-004-25	PH7/10.16-BU76	Additional mating connector for load terminal 3-phase load
63-000-005-25	PH2/7.62-ST16	Additional mating connector for sense terminal of one channel
63-000-004-00	SENSADAPT/PH2/POK/1200V	Sense adapter from Phoenix PH2 to 4 mm touch-protected binding post, max. 1200 V
67-036-020-25	K-MS-ACL	Master-Slave cable I/O port (2 m)
67-001-020-25	Patch cable 2 m	Patch-Kabel 1:1 blue, 2 m
63-000-006-25	SubD25 Doubler	Adapter 1x Sub-D 25 male connector to 2x Sub-D 25 female connector for I/O port
49-001-000-25	SX	Modified setting range for ACL series only after consulting H&H
49-002-000-25	SSX	Customized setting range for ACL series only after consulting H&H

Load cables see starting at page 127

Setting Menu

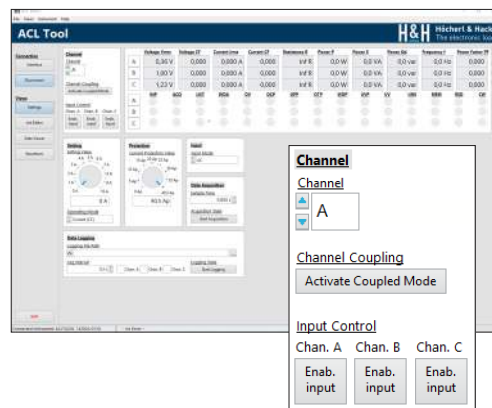

The ACL Tool is a control software for electronic loads of ACL series. Besides the "Channel Coupling" setting, which is useful for three-phase applications, the load inputs of the existing channels can be controlled directly from any function view.

www.hoecherl-hackl.com

-> Download area

Basic Settings

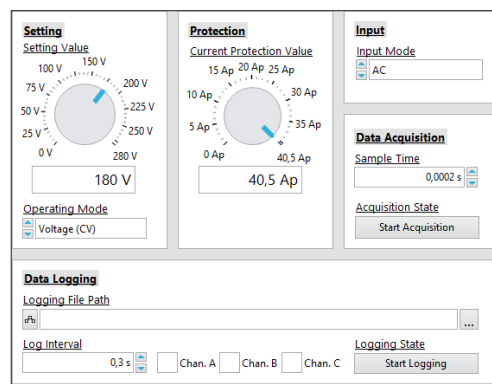

The most important device settings are made in the main window (Basic Settings). These are, in addition to the basic operating mode of the control with the associated setpoint, the peak value of the current protection, AC or DC mode and the data acquisition. There are two different types of data acquisition: a high-resolution one, whose measurement data is stored internally in the load, and a low-resolution one for long measurement processes, which is controlled by the software tool and saves the data to a CSV file on the PC.

Waveforms

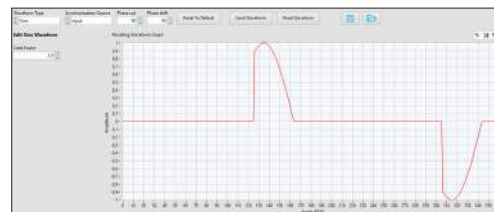

Sinusoidal waveform

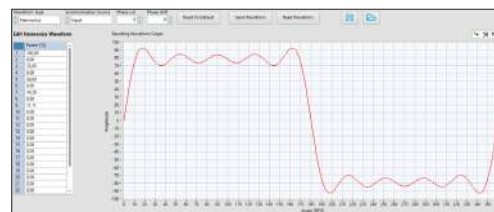

Harmonic waveform

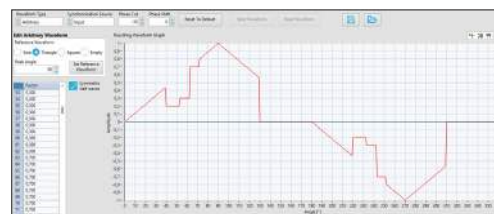

Arbitrary waveform

In the "Waveform Editor" function view, the AC waveform of the load current and its synchronization source can be configured. The waveforms can be created, edited, exported and imported in the ACL tool.

All waveforms can be modified by crest factor, phase cut and phase shift. Phase shifting is only possible in combination with crest factor or phase cutting.

- **Sinusoidal waveform**
- **Harmonic waveform**
A harmonic waveform can be configured by entering the percentages of even and odd harmonics up to the 25th order.
- **Arbitrary waveform**
Arbitrary waveforms are possible with 360 individually editable points. For ease of use, the arbitrary waveform can be derived from a sinusoidal, triangular or rectangular reference waveform.

List Editor

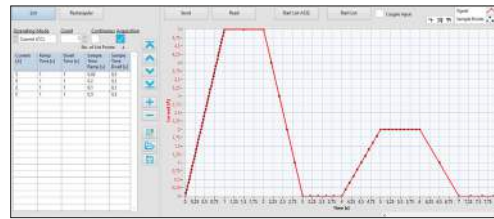

The „List“ function view offers the following functions and settings:

- Defining a load profile in the chosen operating mode
- Number of iterations
- Synchronous data acquisition with individual sample rate for each load profile section
- Loading a *.LST load profile
- Saving the generated load profile as *.LST file (e.g. for direct list import from a USB mass storage device at the electronic load)

Rectangle Editor

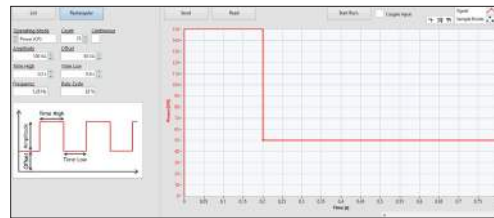

In the "Rectangular" function view, a simple square wave signal is defined by amplitude, offset, dwell time "Time High" as well as dwell time "Time Low". From this, frequency and duty cycle are calculated and displayed.

Measurement and Status Bar

	Adm.V	Adm.I	Adm.P	Adm.R	Adm.C	Adm.S	Adm.T	Adm.F	Adm.D	Adm.H	Adm.L
A	0.00 V	0.000	0.00 mW	0.000	0.00 R	0.00 W	0.00 W	0.00 var	0.00 Hz	0.000	
I	0.00 V	0.000	0.00 mW	0.000	0.00 R	0.00 W	0.00 W	0.00 var	0.00 Hz	0.000	
C	0.00 V	0.000	0.00 mW	0.000	0.00 R	0.00 W	0.00 W	0.00 var	0.00 Hz	0.000	

The display elements of the measured value and status bar show currently measured values as well as important status signals of all available channels of the system.

Data Viewer

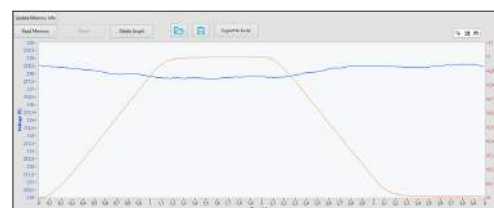

Measured values from the device's own measurement memory can be read from the device using the Data Viewer or as a CSV file from a storage medium and displayed graphically. The data can then in turn be saved as a CSV file on a memory medium for further processing.

Model (Order Number)	ACLS528	ACLS1028	ACLS1428	ACLS2828	ACLS4228
Frequency	DC, 40 ... 1,000 Hz	DC, 40 ... 1,000 Hz	DC, 40 ... 1,000 Hz	DC, 40 ... 1,000 Hz	DC, 40 ... 1,000 Hz
Maximum AC input voltage VmaxAC	280 V AC	280 V AC	280 V AC	280 V AC	280 V AC
Maximum DC input voltage VmaxDC	400 V DC	400 V DC	400 V DC	400 V DC	400 V DC
Minimum input voltage Vmin ¹⁾	6 V	6 V	6 V	6 V	6 V
Maximum current Imax	4 A	8 A	10 A	20 A	30 A
Maximum peak current I _{pmax} ²⁾	16 A	32 A	40 A	80 A	120 A
Power	500 W	1,000 W	1,400 W	2,800 W	4,200 W
Resistance	1.5 ... 991 Ω	0.75 ... 496 Ω	0.6 ... 396 Ω	0.3 ... 198 Ω	0.2 ... 132 Ω
Rise/fall time ³⁾	20 μs	20 μs	25 μs	20 μs	11 μs
Input capacity DC mode ca.	0,2 μF	0,3 μF	3,5 μF	7 μF	11 μF
Load terminals ⁴⁾ rear	SBUS4-32	SBUS4-32	PH3/7.62-ST41	PH3/7.62-ST41	PH3/7.62-ST41
Mains voltage ⁵⁾	1/N/PE AC 230 V 50 ... 60 Hz	1/N/PE AC 230 V 50 ... 60 Hz	1/N/PE AC 230 V 50 ... 60 Hz	1/N/PE AC 230 V 50 ... 60 Hz	1/N/PE AC 230 V 50 ... 60 Hz
Mains voltage toggleable ⁵⁾	1/N/PE AC 115 V 50 ... 60 Hz	1/N/PE AC 115 V 50 ... 60 Hz	1/N/PE AC 115 V 50 ... 60 Hz	1/N/PE AC 115 V 50 ... 60 Hz	1/N/PE AC 115 V 50 ... 60 Hz
Power consumption	115 VA	178 VA	225 VA	380 VA	540 VA
Noise max. ca. ⁶⁾	70 dB(A)	71 dB(A)	72 dB(A)	72 dB(A)	73 dB(A)
Weight ca.	13.5 kg	15.5 kg	29.5 kg	35 kg	41 kg
Housing / 3D model ⁷⁾	19", 2 U / ACL_M14	19", 2 U / ACL_M14	19", 5 U / ACL_M8	19", 5 U / ACL_M8	19", 5 U / ACL_M8

Model (Order Number)	ACLS5628	ACLS7028	ACLS8428	ACLS9828	ACLS11228
Frequency	DC, 40 ... 1,000 Hz	DC, 40 ... 1,000 Hz	DC, 40 ... 1,000 Hz	DC, 40 ... 1,000 Hz	DC, 40 ... 1,000 Hz
Maximum AC input voltage VmaxAC	280 V AC	280 V AC	280 V AC	280 V AC	280 V AC
Maximum DC input voltage VmaxDC	400 V DC	400 V DC	400 V DC	400 V DC	400 V DC
Minimum input voltage Vmin ¹⁾	6 V	6 V	6 V	6 V	6 V
Maximum current Imax	40 A	50 A	60 A	70 A	80 A
Maximum peak current I _{pmax} ²⁾	160 A	200 A	240 A	280 A	320 A
Power	5,600 W	7,000 W	8,400 W	9,800 W	11,200 W
Resistance	0.15 ... 99 Ω	0.12 ... 79 Ω	0.10 ... 66 Ω	0.09 ... 57 Ω	0.08 ... 50 Ω
Rise/fall time ³⁾	20 μs	20 μs	10 μs	15 μs	20 μs
Input capacity DC mode ca.	14 μF	18 μF	21 μF	25 μF	28 μF
Load terminals ⁴⁾ rear	PH3/7.62-ST41	PH3/10.16-ST76	PH3/10.16-ST76	PH3/15-ST125	PH3/15-ST125
Mains voltage ⁵⁾	1/N/PE AC 230 V 50 ... 60 Hz	1/N/PE AC 230 V 50 ... 60 Hz	1/N/PE AC 230 V 50 ... 60 Hz	1/N/PE AC 230 V 50 ... 60 Hz	1/N/PE AC 230 V 50 ... 60 Hz
Mains voltage toggleable ⁵⁾	1/N/PE AC 115 V 50 ... 60 Hz	1/N/PE AC 115 V 50 ... 60 Hz	1/N/PE AC 115 V 50 ... 60 Hz	1/N/PE AC 115 V 50 ... 60 Hz	-
Power consumption	650 VA	800 VA	1055 VA	1175 VA	1160 VA
Noise max. ca. ⁶⁾	74 dB(A)	74 dB(A)	75 dB(A)	75 dB(A)	75 dB(A)
Weight ca.	55 kg	59 kg	74 kg	88 kg	100 kg
Housing / 3D model ⁷⁾	19", 8 U / ACL_M9	19", 8 U / ACL_M9	19", 10 U / ACL_M10	19", 13 U / ACL_M11	19", 13 U / ACL_M11

1. Minimum input voltage for maximum static load current.
 2. Maximum peak current at maximum crest factor.
 3. Rise and fall times are from 10 ... 90 % and 90 ... 10 % of maximum current (CC mode, tolerance ±20 %).
 4. Description of available terminals beginning at page 123.
 5. Mains voltage tolerance: ±10 %.
 6. Measured at the front in distance of 1 m.
 7. 1 U = 44.45 mm. Detailed dimensions by means of 3D models at www.hoercherl-hackl.com/downloads.

Model (Order Number)	ACLS12628	ACLS14028	ACLS15428RV ⁸⁾	ACLS16828RV ⁸⁾	ACLS18228RV ⁸⁾
Frequency	DC, 40 ... 1,000 Hz	DC, 40 ... 1,000 Hz	DC, 40 ... 1,000 Hz	DC, 40 ... 1,000 Hz	DC, 40 ... 1,000 Hz
Maximum AC input voltage V _{maxAC}	280 V AC	280 V AC	280 V AC	280 V AC	280 V AC
Maximum DC input voltage V _{maxDC}	400 V DC	400 V DC	400 V DC	400 V DC	400 V DC
Minimum input voltage V _{min} ¹⁾	6 V	6 V	30 V	30 V	30 V
Maximum current I _{max}	90 A	100 A	110 A	120 A	120 A
Maximum peak current I _{pmax} ²⁾	360 A	400 A	440 A	480 A	480 A
Power	12,600 W	14,000 W	15,400 W	16,800 W	18,200 W
Resistance	0.07 ... 44 Ω	0.06 ... 40 Ω	0.27 ... 36 Ω	0.25 ... 33 Ω	0.25 ... 33 Ω
Rise/fall time ³⁾	20 μs	20 μs	20 μs	20 μs	20 μs
Input capacity DC mode ca.	32 μF	35 μF	39 μF	43 μF	46 μF
Load terminals ⁴⁾ rear	PH3/15-ST125	PH3/15-ST125	PH3/15-ST125	PH3/15-ST125	PH3/15-ST125
Mains voltage ⁵⁾	1/N/PE AC 230 V 50 ... 60 Hz	1/N/PE AC 230 V 50 ... 60 Hz	1/N/PE AC 230 V 50 ... 60 Hz	1/N/PE AC 230 V 50 ... 60 Hz	1/N/PE AC 230 V 50 ... 60 Hz
Mains voltage toggleable ⁵⁾	-	-	1/N/PE AC 115 V 50 ... 60 Hz	1/N/PE AC 115 V 50 ... 60 Hz	1/N/PE AC 115 V 50 ... 60 Hz
Power consumption	1300 VA	1440 VA	650 VA	755 VA	770 VA
Noise max. ca. ⁶⁾	76 dB(A)	80 dB(A)	80 dB(A)	81 dB(A)	82 dB(A)
Weight ca.	107 kg	116 kg	121 kg	105 kg	130 kg
Housing / 3D model ⁷⁾	19", 13 U / ACL_M11	19", 16 U / ACL_M12	19", 14 U / ACL_M21	19", 14 U / ACL_M21	19", 17 U / ACL_M22

Model (Order Number)	ACLS19628RV ⁸⁾	ACLS21028RV ⁸⁾	ACLS22428RV ⁸⁾
Frequency	DC, 40 ... 1,000 Hz	DC, 40 ... 1,000 Hz	DC, 40 ... 1,000 Hz
Maximum AC input voltage V _{maxAC}	280 V AC	280 V AC	280 V AC
Maximum DC input voltage V _{maxDC}	400 V DC	400 V DC	400 V DC
Minimum input voltage V _{min} ¹⁾	30 V	30 V	30 V
Maximum current I _{max}	120 A	120 A	120 A
Maximum peak current I _{pmax} ²⁾	480 A	480 A	480 A
Power	19,600 W	21,000 W	22,400 W
Resistance	0.25 ... 33 Ω	0.25 ... 33 Ω	0.25 ... 33 Ω
Rise/fall time ³⁾	20 μs	20 μs	15 μs
Input capacity DC mode ca.	50 μF	53 μF	56 μF
Load terminals ⁴⁾ rear	PH3/15-ST125	PH3/15-ST125	PH3/15-ST125
Mains voltage ⁵⁾	1/N/PE AC 230 V 50 ... 60 Hz	1/N/PE AC 230 V 50 ... 60 Hz	1/N/PE AC 230 V 50 ... 60 Hz
Mains voltage toggleable ⁵⁾	1/N/PE AC 115 V 50 ... 60 Hz	1/N/PE AC 115 V 50 ... 60 Hz	1/N/PE AC 115 V 50 ... 60 Hz
Power consumption	840 VA	900 VA	1,000 VA
Noise max. ca. ⁶⁾	82 dB(A)	83 dB(A)	83 dB(A)
Weight ca.	138 kg	146 kg	140 kg
Housing / 3D model ⁷⁾	19", 17 U / ACL_M22	19", 17 U / ACL_M22	19", 20 U / ACL_M23

1. Minimum input voltage for maximum static load current.
2. Maximum peak current at maximum crest factor.
3. Rise and fall times are from 10 ... 90 % and 90 ... 10 % of maximum current (CC mode, tolerance ±20 %).
4. Description of available terminals beginning at page 123.
5. Mains voltage tolerance: ±10 %.
6. Measured at the front in distance of 1 m.
7. 1 U = 44.45 mm. Detailed dimensions by means of 3D models at www.hoercherl-hackl.com/downloads.
8. RV: Restricted Voltage. Models with increased minimum voltage.

Model (Order Number)	ACLS550	ACLS1050	ACLS1450	ACLS2850	ACLS4250
Frequency	DC, 40 ... 1,000 Hz	DC, 40 ... 1,000 Hz	DC, 40 ... 1,000 Hz	DC, 40 ... 1,000 Hz	DC, 40 ... 1,000 Hz
Maximum AC input voltage V _{maxAC}	500 V AC	500 V AC	500 V AC	500 V AC	500 V AC
Maximum DC input voltage V _{maxDC}	700 V DC	700 V DC	700 V DC	700 V DC	700 V DC
Minimum input voltage V _{min} ¹⁾	10 V	10 V	10 V	10 V	10 V
Maximum current I _{max}	2 A	4 A	5 A	10 A	15 A
Maximum peak current I _{pmax} ²⁾	8 A	16 A	20 A	40 A	60 A
Power	500 W	1,000 W	1,400 W	2,800 W	4,200 W
Resistance	5.0 ... 3540 Ω	2.5 ... 1770 Ω	2.0 ... 1416 Ω	1.0 ... 708 Ω	0.67 ... 472 Ω
Rise/fall time ³⁾	20 μs	20 μs	20 μs	10 μs	20 μs
Input capacity DC mode ca.	0.2 μF	0.3 μF	3.3 μF	7 μF	10 μF
Load terminals ⁴⁾ rear	SBUS4-32	SBUS4-32	PH3/7.62-ST41	PH3/7.62-ST41	PH3/7.62-ST41
Mains voltage ⁵⁾	1/N/PE AC 230 V 50 ... 60 Hz	1/N/PE AC 230 V 50 ... 60 Hz	1/N/PE AC 230 V 50 ... 60 Hz	1/N/PE AC 230 V 50 ... 60 Hz	1/N/PE AC 230 V 50 ... 60 Hz
Mains voltage toggleable ⁵⁾	1/N/PE AC 115 V 50 ... 60 Hz	1/N/PE AC 115 V 50 ... 60 Hz	1/N/PE AC 115 V 50 ... 60 Hz	1/N/PE AC 115 V 50 ... 60 Hz	1/N/PE AC 115 V 50 ... 60 Hz
Power consumption	110 VA	140 VA	150 VA	270 VA	300 VA
Noise max. ca. ⁶⁾	70 dB(A)	71 dB(A)	71 dB(A)	72 dB(A)	73 dB(A)
Weight ca.	13.5 kg	16 kg	29 kg	35 kg	43 kg
Housing / 3D model ⁷⁾	19", 2 U / ACL_M14	19", 2 U / ACL_M14	19", 5 U / ACL_M8	19", 5 U / ACL_M8	19", 5 U / ACL_M8

Model (Order Number)	ACLS5650	ACLS7050	ACLS8450	ACLS9850	ACLS11250
Frequency	DC, 40 ... 1,000 Hz	DC, 40 ... 1,000 Hz	DC, 40 ... 1,000 Hz	DC, 40 ... 1,000 Hz	DC, 40 ... 1,000 Hz
Maximum AC input voltage V _{maxAC}	500 V AC	500 V AC	500 V AC	500 V AC	500 V AC
Maximum DC input voltage V _{maxDC}	700 V DC	700 V DC	700 V DC	700 V DC	700 V DC
Minimum input voltage V _{min} ¹⁾	10 V	10 V	10 V	10 V	10 V
Maximum current I _{max}	20 A	25 A	30 A	35 A	40 A
Maximum peak current I _{pmax} ²⁾	80 A	100 A	120 A	140 A	160 A
Power	5,600 W	7,000 W	8,400 W	9,800 W	11,200 W
Resistance	0.5 ... 354 Ω	0.40 ... 283 Ω	0.33 ... 236 Ω	0.29 ... 202 Ω	0.25 ... 177 Ω
Rise/fall time ³⁾	22 μs	20 μs	10 μs	20 μs	20 μs
Input capacity DC mode ca.	13 μF	16 μF	20 μF	23 μF	26 μF
Load terminals ⁴⁾ rear	PH3/7.62-ST41	PH3/7.62-ST41	PH3/7.62-ST41	PH3/7.62-ST41	PH3/10.16-ST76
Mains voltage ⁵⁾	1/N/PE AC 230 V 50 ... 60 Hz	1/N/PE AC 230 V 50 ... 60 Hz	1/N/PE AC 230 V 50 ... 60 Hz	1/N/PE AC 230 V 50 ... 60 Hz	1/N/PE AC 230 V 50 ... 60 Hz
Mains voltage toggleable ⁵⁾	1/N/PE AC 115 V 50 ... 60 Hz	1/N/PE AC 115 V 50 ... 60 Hz	1/N/PE AC 115 V 50 ... 60 Hz	1/N/PE AC 115 V 50 ... 60 Hz	1/N/PE AC 115 V 50 ... 60 Hz
Power consumption	500 VA	500 VA	800 VA	675 VA	760 VA
Noise max. ca. ⁶⁾	74 dB(A)	74 dB(A)	74 dB(A)	75 dB(A)	75 dB(A)
Weight ca.	53 kg	59 kg	64 kg	79 kg	84 kg
Housing / 3D model ⁷⁾	19", 8 U / ACL_M17	19", 8 U / ACL_M17	19", 8 U / ACL_M17	19", 11 U / ACL_M15	19", 11 U / ACL_M16

1. Minimum input voltage for maximum static load current.
 2. Maximum peak current at maximum crest factor.
 3. Rise and fall times are from 10 ... 90 % and 90 ... 10 % of maximum current (CC mode, tolerance ±20 %).
 4. Description of available terminals beginning at page 123.
 5. Mains voltage tolerance: ±10 %.
 6. Measured at the front in distance of 1 m.
 7. 1 U = 44.45 mm. Detailed dimensions by means of 3D models at www.hoecherl-hackl.com/downloads.

Model (Order Number)	ACLS12650	ACLS14050	ACLS15450	ACLS16850	ACLS18250
Frequency	DC, 40 ... 1,000 Hz	DC, 40 ... 1,000 Hz	DC, 40 ... 1,000 Hz	DC, 40 ... 1,000 Hz	DC, 40 ... 1,000 Hz
Maximum AC input voltage VmaxAC	500 V AC	500 V AC	500 V AC	500 V AC	500 V AC
Maximum DC input voltage VmaxDC	700 V DC	700 V DC	700 V DC	700 V DC	700 V DC
Minimum input voltage Vmin ¹⁾	10 V	10 V	10 V	10 V	10 V
Maximum current Imax	45 A	50 A	55 A	60 A	65 A
Maximum peak current Ipmx ²⁾	180 A	200 A	220 A	240 A	260 A
Power	12,600 W	14,000 W	15,400 W	16,800 W	18,200 W
Resistance	0.22 ... 157 Ω	0.20 ... 142 Ω	0.18 ... 129 Ω	0.17 ... 118 Ω	0.15 ... 109 Ω
Rise/fall time ³⁾	20 μs	18 μs	20 μs	20 μs	20 μs
Input capacity DC mode ca.	30 μF	33 μF	36 μF	39 μF	43 μF
Load terminals ⁴⁾ rear	PH3/10.16-ST76	PH3/10.16-ST76	PH3/10.16-ST76	PH3/10.16-ST76	PH3/10.16-ST76
Mains voltage ⁵⁾	1/N/PE AC 230 V 50 ... 60 Hz	1/N/PE AC 230 V 50 ... 60 Hz	1/N/PE AC 230 V 50 ... 60 Hz	1/N/PE AC 230 V 50 ... 60 Hz	1/N/PE AC 230 V 50 ... 60 Hz
Mains voltage toggleable ⁵⁾	1/N/PE AC 115 V 50 ... 60 Hz	1/N/PE AC 115 V 50 ... 60 Hz	1/N/PE AC 115 V 50 ... 60 Hz	1/N/PE AC 115 V 50 ... 60 Hz	1/N/PE AC 115 V 50 ... 60 Hz
Power consumption	850 VA	1150 VA	1030 VA	1120 VA	1200 VA
Noise max. ca. ⁶⁾	76 dB(A)	77 dB(A)	80 dB(A)	81 dB(A)	82 dB(A)
Weight ca.	91 kg	99 kg	121 kg	126 kg	130 kg
Housing / 3D model ⁷⁾	19", 11 U / ACL_M16	19", 14 U / ACL_M20	19", 16 U / ACL_M18	19", 16 U / ACL_M18	19", 19 U / ACL_M19

Model (Order Number)	ACLS19650	ACLS21050
Frequency	DC, 40 ... 1,000 Hz	DC, 40 ... 1,000 Hz
Maximum AC input voltage VmaxAC	500 V AC	500 V AC
Maximum DC input voltage VmaxDC	700 V DC	700 V DC
Minimum input voltage Vmin ¹⁾	10 V	10 V
Maximum current Imax	70 A	75 A
Maximum peak current Ipmx ²⁾	140 A	160 A
Power	19,600 W	21,000 W
Resistance	0.14 ... 101 Ω	0.13 ... 94 Ω
Rise/fall time ³⁾	20 μs	20 μs
Input capacity DC mode ca.	46 μF	49 μF
Load terminals ⁴⁾ rear	PH3/15-ST125	PH3/15-ST125
Mains voltage ⁵⁾	1/N/PE AC 230 V 50 ... 60 Hz	1/N/PE AC 230 V 50 ... 60 Hz
Mains voltage toggleable ⁵⁾	1/N/PE AC 115 V 50 ... 60 Hz	1/N/PE AC 115 V 50 ... 60 Hz
Power consumption	1290 VA	1380 VA
Noise max. ca. ⁶⁾	82 dB(A)	83 dB(A)
Weight ca.	138 kg	146 kg
Housing / 3D model ⁷⁾	19", 19 U / ACL_M19	19", 19 U / ACL_M19

1. Minimum input voltage for maximum static load current.
2. Maximum peak current at maximum crest factor.
3. Rise and fall times are from 10 ... 90 % and 90 ... 10 % of maximum current (CC mode, tolerance ±20 %).
4. Description of available terminals beginning at page 123.
5. Mains voltage tolerance: ±10 %.
6. Measured at the front in distance of 1 m.
7. 1 U = 44.45 mm. Detailed dimensions by means of 3D models at www.hoecherl-hackl.com/downloads.

Model (Order Number)	ACLT4228	ACLT8428	ACLT12628	ACLT16828	ACLT21028
Frequency ¹⁾	DC, 40 ... 1,000 Hz	DC, 40 ... 1,000 Hz	DC, 40 ... 1,000 Hz	DC, 40 ... 1,000 Hz	DC, 40 ... 1,000 Hz
Maximum AC input voltage VmaxAC ¹⁾	280 V AC	280 V AC	280 V AC	280 V AC	280 V AC
Maximum DC input voltage VmaxDC ¹⁾	400 V DC	400 V DC	400 V DC	400 V DC	400 V DC
Minimum input voltage Vmin ¹⁾²⁾	10 V	10 V	10 V	10 V	10 V
Maximum current Imax ¹⁾	10 A	20 A	30 A	40 A	50 A
Maximum peak current Ipmx ¹⁾³⁾	40 A	80 A	120 A	160 A	200 A
Power ¹⁾	1,400 W	2,800 W	4,200 W	5,600 W	7,000 W
Resistance ¹⁾	0.6 ... 396 Ω	0.3 ... 198 Ω	0.2 ... 132 Ω	0.15 ... 99 Ω	0.12 ... 79 Ω
Rise/fall time ¹⁾⁴⁾	15 μs	10 μs	10 μs	18 μs	20 μs
Input capacity DC mode ca. ¹⁾	4 μF	7 μF	11 μF	14 μF	18 μF
Load terminals ⁵⁾	PH7/10.16-ST76	PH7/10.16-ST76	PH7/10.16-ST76	PH7/10.16-ST76	PH7/10.16-ST76
Mains voltage ⁶⁾	1/N/PE AC 230 V 50 ... 60 Hz	1/N/PE AC 230 V 50 ... 60 Hz	1/N/PE AC 230 V 50 ... 60 Hz	1/N/PE AC 230 V 50 ... 60 Hz	1/N/PE AC 230 V 50 ... 60 Hz
Mains voltage toggleable ⁶⁾	1/N/PE AC 115 V 50 ... 60 Hz	1/N/PE AC 115 V 50 ... 60 Hz	1/N/PE AC 115 V 50 ... 60 Hz	-	-
Power consumption	480 VA	1055 VA	1330 VA	1775 VA	2170 VA
Noise max. ca. ⁷⁾	72 dB(A)	75 dB(A)	74 dB(A)	77 dB(A)	76 dB(A)
Weight ca.	41 kg	74 kg	98 kg	125 kg	151 kg
Housing ⁸⁾	19", 6 U / ACL_M2	19", 10 U / ACL_M3	19", 14 U / ACL_M4	19", 18 U / ACL_M5	19", 22 U / ACL_M6

Model (Order Number)	ACLT25228
Frequency ¹⁾	DC, 40 ... 1,000 Hz
Maximum AC input voltage VmaxAC ¹⁾	280 V AC
Maximum DC input voltage VmaxDC ¹⁾	400 V DC
Minimum input voltage Vmin ¹⁾²⁾	10 V
Maximum current Imax ¹⁾	60 A
Maximum peak current Ipmx ¹⁾³⁾	240 A
Power ¹⁾	8,400 W
Resistance ¹⁾	0.10 ... 66 Ω
Rise/fall time ¹⁾⁴⁾	20 μs
Input capacity DC mode ca. ¹⁾	21 μF
Load terminals ⁵⁾	PH7/10.16-ST76
Mains voltage ⁶⁾	1/N/PE AC 230 V 50 ... 60 Hz
Mains voltage toggleable ⁶⁾	-
Power consumption	2600 VA
Noise max. ca. ⁷⁾	78 dB(A)
Weight ca.	179 kg
Housing ⁸⁾	19", 26 U / ACL_M7

1. Per phase
2. Minimum input voltage for maximum static load current.
3. Maximum peak current at maximum crest factor.
4. Rise and fall times are from 10 ... 90 % and 90 ... 10 % of maximum current (CC mode, tolerance ±20 %).
5. Description of available terminals beginning at page 123.
6. Mains voltage tolerance: ±10 %.
7. Measured at the front in distance of 1 m.
8. 1 U = 44,45 mm. Detailed dimensions by means of 3D models at www.hoecherl-hackl.com/downloads.

Model (Order Number)	ACLT4250	ACLT8450	ACLT12650	ACLT16850	ACLT21050
Frequency ¹⁾	DC, 40 ... 1,000 Hz	DC, 40 ... 1,000 Hz	DC, 40 ... 1,000 Hz	DC, 40 ... 1,000 Hz	DC, 40 ... 1,000 Hz
Maximum AC input voltage V _{maxAC} ¹⁾	500 V AC	500 V AC	500 V AC	500 V AC	500 V AC
Maximum DC input voltage V _{maxDC} ¹⁾	700 V DC	700 V DC	700 V DC	700 V DC	700 V DC
Minimum input voltage V _{min} ^{1) 2)}	10 V	10 V	10 V	10 V	10 V
Maximum current I _{max} ¹⁾	5 A	10 A	15 A	20 A	25 A
Maximum peak current I _{pmax} ^{1) 3)}	20 A	40 A	60 A	80 A	100 A
Power ¹⁾	1,400 W	2,800 W	4,200 W	5,600 W	7,000 W
Resistance ¹⁾	2.0 ... 1416 Ω	1.0 ... 708 Ω	0.67 ... 472 Ω	0.5 ... 354 Ω	0.40 ... 283 Ω
Rise/fall time ^{1) 4)}	20 μs	11 μs	11 μs	10 μs	20 μs
Input capacity DC mode ca. ¹⁾	3 μF	6.6 μF	10 μF	13 μF	16 μF
Load terminals ⁵⁾	PH7/10.16-ST76	PH7/10.16-ST76	PH7/10.16-ST76	PH7/10.16-ST76	PH7/10.16-ST76
Mains voltage ⁶⁾	1/N/PE AC 230 V 50 ... 60 Hz	1/N/PE AC 230 V 50 ... 60 Hz	1/N/PE AC 230 V 50 ... 60 Hz	1/N/PE AC 230 V 50 ... 60 Hz	1/N/PE AC 230 V 50 ... 60 Hz
Mains voltage toggleable ⁶⁾	1/N/PE AC 115 V 50 ... 60 Hz	1/N/PE AC 115 V 50 ... 60 Hz	1/N/PE AC 115 V 50 ... 60 Hz	-	-
Power consumption	380 VA	700 VA	960 VA	1315 VA	1890 VA
Noise max. ca. ⁷⁾	70 dB(A)	74 dB(A)	77 dB(A)	76 dB(A)	76 dB(A)
Weight ca.	41 kg	71 kg	99 kg	127 kg	151 kg
Housing ⁸⁾	19", 6 U / ACL_M2	19", 10 U / ACL_M3	19", 14 U / ACL_M4	19", 18 U / ACL_M5	19", 22 U / ACL_M6

Model (Order Number)	ACLT25250
Frequency ¹⁾	DC, 40 ... 1,000 Hz
Maximum AC input voltage V _{maxAC} ¹⁾	500 V AC
Maximum DC input voltage V _{maxDC} ¹⁾	700 V DC
Minimum input voltage V _{min} ^{1) 2)}	10 V
Maximum current I _{max} ¹⁾	30 A
Maximum peak current I _{pmax} ^{1) 3)}	120 A
Power ¹⁾	8,400 W
Resistance ¹⁾	0.33 ... 236 Ω
Rise/fall time ^{1) 4)}	20 μs
Input capacity DC mode ca. ¹⁾	20 μF
Load terminals ⁵⁾	PH7/10.16-ST76
Mains voltage ⁶⁾	1/N/PE AC 230 V
Mains voltage toggleable ⁶⁾	-
Power consumption	1,865 VA
Noise max. ca. ⁷⁾	80 dB(A)
Weight ca.	179 kg
Housing ⁸⁾	19", 26 U / ACL_M7

ACLT4228

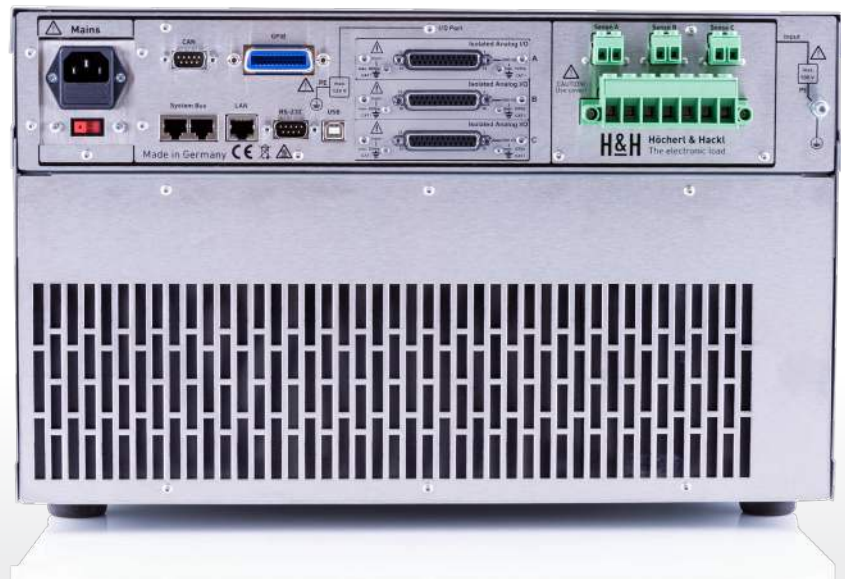

1. Per phase
2. Minimum input voltage for maximum static load current.
3. Maximum peak current at maximum crest factor.
4. Rise and fall times are from 10 ... 90 % and 90 ... 10 % of maximum current (CC mode, tolerance ±20 %).
5. Description of available terminals beginning at page 123.
6. Mains voltage tolerance: ±10 %.
7. Measured at the front in distance of 1 m.
8. 1 U = 44.45 mm. Detailed dimensions by means of 3D models at www.hoechert-hackl.com/downloads.

Operating modes		
Basic operating modes	CC, CV, CR, CP	
Frequency		
Frequency range	DC, 40 ... 1,000 Hz	
Synchronization time	1 ... 5 periods of input signal	
Synchronization time for rapidly changing frequencies or when connecting the input voltage	Synchronization to input/extern	Pre-synchronization to line voltage
	max. 500 ms	0 ms
Accuracy of voltage setting ¹⁾		
	of setting	of corresponding range
Voltage	DC	±0.5 %
	AC	±1 %
		±0.1 % ±0.2 %
Accuracy of current setting ¹⁾		
	of setting	of corresponding range
Current	DC	±0.2 %
	40 ... 400 Hz	±0.5 %
	> 400 Hz	±0.75 %
Resolution	14 bits	
Total harmonic distortion ²⁾	40 ... 400 Hz	<2 %
	> 400 Hz	<4 %
Accuracy of resistance setting ¹⁾		
	of setting	of corresponding range
Resistance ³⁾	±1.5 %	±1 % of resistance range ±0.3 % of current range
Accuracy of power setting ¹⁾		
	of setting	of corresponding range
Power ⁴⁾	DC, 40 ... 400 Hz	±1 %
	> 400 Hz	±1.5 %
Power ⁵⁾	DC, 40 ... 400 Hz	±3 %
	> 400 Hz	±5 %
Resolution	calculated from resolutions of voltage and current measurement and current setting	
Rise and fall time		
CC mode	see model overview	
CP, CV mode	DC	ca. 10 ms
	AC	ca. 1 s
Accuracy of adjustable protections		
	of setting	of current range
Overcurrent protection	±1 %	±0.2 %
Resolution	12 bits	
Waveforms (Resolution: 360 points in 1° steps)		
Sine	as fundamental waveform	
Arbitrary waveforms	based on sine, triangle or rectangle, editable pointwise	
Harmonics	2 nd to 25 th Harmonics in variable proportions superimposable to the fundamental wave	
Crest factor	1.4142 ... 4.0 with automatic amplitude correction	
Phase cut	-180 ... 180°	

Phase shift	-180 ... 180° (only in combination with crest factor or phase cut, no capacitive or inductive load)	
Measurement functions		
Numeric display	rms value voltage, rms value current, resistance, active power, apparent power, reactive power, frequency, power factor, crest factor	
Graphical display	last period of current and voltage with 360 points, temporal progression of rms values of voltage, current and/or power of focused channel	
Accuracy of measurements/display		
	of measured (real) value	of corresponding range
Voltage	DC	±0.2 %
	AC	±0.3 %
		±0.05 % ±1 digit ±0.1 % ±1 digit
Current	DC	±0.2 %
	40 ... 400 Hz	±0.5 %
	> 400 Hz	±0.75 %
		±0.1 % ±1 digit ±0.3 % ±1 digit ±0.5 % ±1 digit
Resolution	16 bits	
Resistance	calculated from voltage and current	
Power	calculated from voltage and current	
Sampling time	200 µs, triggerable	
Frequency	±0.1 % ±0.1 Hz	
Dynamic function (LIST)		
Number of load levels	max. 300, with corresponding ramp and dwell times	
	min.	max.
Dwell time	200 µs	1.000 s
Ramp time	0 s	1.000 s
Resolution	200 µs	
Accuracy of setting times	±0.02 %	
Delay at triggered start	max. 300 µs	
Data acquisition		
to external USB flash drive		
Sampling time	0.5 ... 30 s, resolution 100 ms	
Measurement data	timestamp, voltage, current	
Number of measurement points	limited by USB memory capacity	
Dateformat	.csv	
to internal memory		
Sampling time	200 µs ... 1,000 s, resolution 200 µs, static or synchronized with LIST function	
Measurement data	timestamp, voltage, current	
Number of measurement points	max. 40,000	
Settings memory		
Number of user settings	9, selectable (incl. programmed waveform and List) 1 for last settings at power-off or power fail	
I/O port (option ACL06): control inputs and outputs		
Control inputs	mode selection load input on - off selection of control source (internal, external) input mode (AC, DC) synchronization source (input, line, extern) synchronization input remote shut-down trigger input (low-active)	
Dig. input level	logical low: 0 ... 0.8 V, logical high: 3 ... 30 V	

The specified accuracies refer to an ambient temperature of 23 ±5 °C. The specified accuracies are valid when the sense lines are connected and when the unit is connected to undisturbed voltages (ripple and noise < 0.1 %). At voltages with higher disturbance values the accuracy can change for the worse.

1. The accuracy applies for the specified frequencies. At higher frequencies the accuracy decreases.
2. Measured at I_{max}. THD increases at lower currents.
3. At 5 % V_{max} < V < 100 % V_{max} and 5 % I_{max} < I < 100 % I_{max}.
4. At V > 30 % V_{max} and I > 30 % I_{max}.
5. At V < 30 % V_{max} or I < 30 % I_{max}.

Technical Data

Control outputs	load input activation state (low-active) status overload trigger output programmable output
Dig. output level	logical low: 0 ... 0.8 V, logical high: 5 V/24 V selectable, max. 10 mA (push-pull)

I/O port (option ACL06): accuracy analog control 0 ... 10 V for current

	of setting	of corresponding range
Current	DC	±0.2 %
	40 ... 400 Hz	±0.5 %
	> 400 Hz	±0.75 %
Input resistance of analog inputs >10 kΩ		

I/O port (option ACL06): accuracy analog monitor signals 0 ... 7 V / 0 ... 10 V for voltage and current

	of analog signal of real value	offset voltage
Voltage	DC, 40 ... 400 Hz	±0.3 %
	>400 Hz	±0.5 %
Current	DC, 40 ... 400 Hz	±0.5 %
	>400 Hz	±0.75 %
Maximum load capacity 2 kΩ. Analog monitor outputs as proportional AC curve or RMS value, selectable		

I/O port (option ACL06): permissible voltages

	AC mode The external circuit is mains voltage up to 500 V AC with overvoltage category II.	DC mode The external circuit is a DC voltage derived from mains voltage with overvoltage category II.
Vin-io (GND - Input LO)	max. 600 V AC	max. 800 V DC
VioPE (GND - PE)	max. 100 V AC	max. 100 V DC

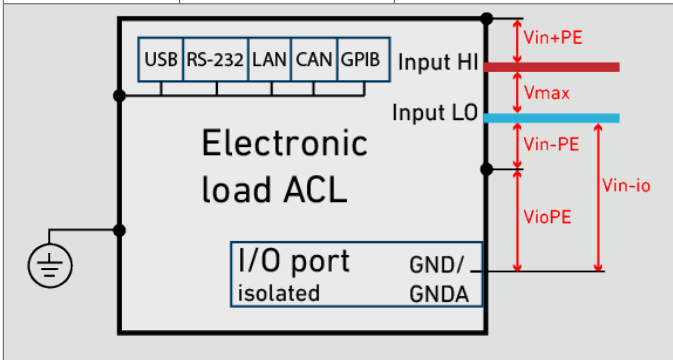

Input

Input resistance	> 50 kΩ at deactivated load input
Input capacity	see model overview
Parallel operation	up to 3 devices in Master-Slave operation
Max. input voltage Vmax	see model overview
Min. input voltage Vmin for max. current	see model overview

Input: permissible voltages

Vin-PE (Input LO - PE)	max. 500 V ¹⁾
Vin+PE (Input HI - PE)	max. 500 V ¹⁾

Power

Continuous power	see model overview (at TA = 21 °C)
Derating	-1.2 %/°C for TA > 21 °C

Protection and Monitoring

Protective devices	overcurrent overpower overtemperature
Monitoring	overvoltage undervoltage (if the input voltage is too low for the set current)

Terminals

Load input	see model overview
Sense	Phoenix PH2/7.62-BU16, see page 123 and following

Operating conditions

Operating temperature	5 ... 40 °C
Stock temperature	-25 ... 65 °C
Max. operation height	2,000 m over sea level
Pollution degree	2
Max. humidity	80 % at 31 °C, linear decreasing to 50 % at 40 °C
Min. distance rear panel to wall or other objects	70 cm
Cooling	temperature-controlled air cooling
Noise	see model overview
Mains voltage	see model overview
Mains cable	length max. 3 m cross-section of mains leads: 10 A cold device plug: (IEC C13): min. 1 mm ² 16 A cold device plug: (IEC C19): min. 1.5 mm ²
Power consumption	see model overview

Housing

Dimensions, weight	see model overview
Color	front panel RAL7035 (light grey) rear panel stainless steel side panels, top RAL7037 (dusty grey)

Safety and EMV

Protection class	1
Measuring category	CAT II
Electrical safety	DIN EN 61010-1 DIN EN 61010-2-030
EMC	DIN EN 61326-1 DIN EN 55011 DIN EN 61000-3-2 DIN EN 61000-3-3

Standard interfaces

Data interfaces	RS-232, USB, LAN, CAN
I/O port	-

Available options

Data interface	
ACL02	GPIB interface
Hardware extensions	
ACL06 ACL14	galvanically isolated I/O port castors

Calibration, warranty

FCC-ACLxx	Factory Calibration Certificate, twice for free
Warranty	2 years

1. positive/negative DC voltage or RMS value of a sinusoidal AC voltage

Technical data of production series B, rev. 5. Subject to technical changes without notice.